

**Class 3000
Steel Pipe Unions
Socket Welding and Threaded**

**Standard Practice
Developed and Approved by the
Manufacturers Standardization Society of the
Valve and Fittings Industry, Inc.
127 Park Street, NE
Vienna, Virginia 22180
(703) 281-6613**



This MSS Standard Practice was developed under the consensus of MSS Technical Committee 105 and the MSS Coordinating Committee. The content of this Standard Practice is the result of the efforts of competent and concerned volunteers to provide an effective, clear, and non-exclusive specification that will benefit the industry as a whole. This MSS Standard Practice is intended as a basis for common practice by the manufacturer, the user, and the general public. The existence of an MSS Standard Practice does not in itself preclude the manufacture, sale, or use of products not conforming to the Standard Practice. Mandatory conformance is established only by reference in a code, specification, sales contract, or public law, as applicable.

Unless otherwise specifically noted in this MSS SP, any standard referred to herein is identified by the date of issue that was applicable to the referenced standard(s) at the date of issue of this MSS SP. (See Annex A).

Substantive changes in this 2001 edition are "flagged" by parallel bars as shown on the margins of this paragraph. The specific detail of the change may be determined by comparing the material flagged with that in the previous edition

Any part of this standard may be quoted. Credit lines should read 'Extracted from MSS SP-83, 2001, with permission of the publisher, the Manufacturers Standardization Society.' Reproduction prohibited under copyright convention unless written permission is granted by the Manufacturers Standardization Society of the Valve and Fittings Industry, Inc.

Originally Approved 1976

Copyright © 1976 by
Manufacturers Standardization Society
of the
Valve and Fittings Industry, Inc.
Printed in U.S.A.

TABLE OF CONTENTS

<u>SECTION</u>	<u>PAGE</u>
1 SCOPE.....	1
2 PRESSURE RATINGS.....	1
3 SIZE.....	1
4 DESCRIPTION.....	1
5 MARKING.....	2
6 MATERIAL.....	2
7 TESTS.....	2
8 DESIGN AND DIMENSIONS.....	2
9 SOCKET WELDING UNIONS.....	3
10 THREADED UNIONS.....	3
11 NUT THREADS.....	3
12 FINISH.....	3
13 TOLERANCES.....	3
14 NUT TIGHTENING TORQUE.....	3
15 CORROSION PROTECTION.....	3

TABLE 1	Pressure-Temperature Service Rating Class 3000 Carbon and Stainless Steel Unions Socket Welding and Threaded Ends, Imperial Units.....	1
2	Terminology of Parts.....	2
3	Minimum Recommended Nut Tightening Torque, Imperial Units.....	4
4	Class 3000 Carbon and Stainless Steel Pipe Unions Socket Welding Ends, Imperial Units.....	5
5	Class 3000 Carbon and Stainless Steel Pipe Unions Threaded Ends, Imperial Units.....	6
FIGURE 1	Recommended Method for Checking Coincidence of Axis on Threaded Unions.....	4
FIGURE 2	Welding Gap.....	3
ANNEX A	Referenced Standards and Applicable Dates.....	7

CAUTIONARY NOTES REGARDING INSTALLATION OF STEEL UNIONS

- a) Leakage from a union can result when joining pipe ends which are poorly aligned.
- b) Care should be taken to avoid placing unions in lines subject to live loads and bending loads, which may cause leakage.
- c) Care should be taken to prevent damage to the seating surfaces.
- d) Due consideration should be given to the possibility of shock pressure in the system.

NOTE: UNION PARTS FROM DIFFERENT MANUFACTURERS ARE NOT FUNCTIONALLY INTERCHANGEABLE AND SUCH USAGE IS NOT RECOMMENDED.

**STEEL PIPE UNIONS
SOCKET WELDING AND THREADED**

1. SCOPE

1.1 This Standard Practice establishes envelope and other essential dimensionals, finish, tolerances, testing, marking, material, and minimum performance requirements for forged carbon and stainless steel pipe unions, socket welding and threaded ends.

2. PRESSURE RATINGS

2.1 These unions shall be designated as Class 3000 socket welding or threaded and shall carry ratings shown in Table 1.

3. SIZE

3.1 The size of the union is identified by the nominal pipe size.

4. DESCRIPTION

4.1 The complete union shall consist of three parts: male end, female end, and, nut. Equivalent terms are tabulated in Table 2.

**TABLE 1
Pressure-Temperature Service Rating
Class 3000 Carbon and Stainless Steel
Unions Socket Welding & Threaded Ends**

SERVICE TEMP. DEGREE F	NON-SHOCK WORKING PRESSURE			
	psig			
	ASTM A 105 CARBON STEEL	ASTM A 182 F316	ASTM A 182 F304L F316L	ASTM A 182 F304
100	3000	2915	2430	2915
200	2735	2510	2050	2430
300	2655	2265	1835	2140
400	2565	2080	1670	1905
500	2425	1935	1545	1770
600	2220	1830	1460	1680
650	2180	1800	1420	1650
700	2155	1750	1390	1630
750		1710	1360	1610
800		1680	1330	1595
850		1645	1300	1575
900		1595		1555
950		1565		1515
1000		1470		1300

TABLE 2 Terminology of Parts

Preferred Term	Equivalent Terms
Male	Male seat end Tail Piece - Nut Piece - Coupling - Ball End
Female	Female seat end Thread Piece - Body - Head - Cone End
Nut	Union Coupling Nut - Swivel - Ring

4.2 The seating surfaces of the joint will be steel-to-steel, ball-to-cone design. Male and Female ends shall be machined with sockets for socket welding or threaded with internal NPT pipe threads. Male and Female ends and Nuts may be round, polygon, or modified polygon with rounded corners, at the option of the manufacturer. The length of the union ends shall be sufficient to provide a suitable wrenching surface.

5. MARKING

5.1 Each union Nut shall be permanently marked in accordance with MSS SP-25. The marking shall include (but is not limited to) the following:

- Manufacturer's name or trademark.
- Material grade identification- in accordance with the requirements of the applicable ASTM specification listed in Section 6.
Note: Multiple material marking shall be allowed as covered in ASTM material specifications listed in Section 6.1.
- Material lot or heat number for traceability.
- Service designation: 3000 or 3M (M to designate units of 1000)
- The nominal pipe size.

5.2 The Male and Female union ends shall be permanently marked with the following:

- Manufacturer's name or trademark.
- Material grade identification. (See Para. 5.1b)
- Material lot or heat number for traceability.

5.3 All three parts of a union, in compliance with all requirements of this SP, shall be marked SP83.

16. MATERIAL

6.1 The three parts of a union assembly shall be manufactured from materials which have the same requirements for chemical composition, mechanical properties, and applicable heat treatment, except that F304 and F316 union nuts may be used with F304L and F316L end pieces, respectively. Material specification ASTM A 182 applies for stainless steel, grades F304/F304L/F316/F316L. Stainless steel austenitic unions are suitable for use with ASTM A312/A312M pipe.

Note: Multiple Material Marking:

Stainless Steel unions, meeting the chemical and mechanical properties for more than one class or grade, may, at the manufacturer's option, be marked with more than one class or grade designation, such as F304/304L and F316/316L.

Material specification ASTM A 105 applies for carbon steel. Carbon steel unions are suitable for use with ASTM A 106 Grade B pipe as well as lower grades.

6.2 Carbon steel and stainless steel union parts may be forged, formed, or made from wrought bars conforming to the requirements of the melting process, chemical composition, and mechanical property requirements of ASTM A 105 for carbon steel and ASTM A 182 for stainless steel grades.

6.3 Unions may be made from materials of other wrought material by agreement between the manufacturer and the purchaser, but shall not be marked SP83.

7. TESTS

7.1 Pressure testing is not required by this standard.

8. DESIGN AND DIMENSIONS

8.1 **Socket Wall Thickness for Socket Welding Unions.** The socket wall thickness shall be no less than the corresponding values, C, shown in Table 4.

8.2 **Minimum Body Wall Thickness for Socket Welding Unions.** The minimum body wall thickness, other than socket wall, must be equal to or greater than the nominal wall thickness of Schedule 80 pipe of the same size as the union, as established by ASME B36.10M.

8.3 **Minimum Wall Thickness for Threaded Unions.** (Dimension C in Table 5). The minimum wall thickness at the root of the pipe thread at the wrench tight plane, must equal or exceed the nominal wall thickness for Schedule 80 pipe.

8.4 **Other Dimensions.** The dimensions for unions capable of meeting this standard are shown in Table 4 for socket welding unions and Table 5 for threaded unions.

8.5 Union parts from different manufacturers are not functionally interchangeable and such usage is not recommended.

9. **SOCKET WELDING UNIONS**

9.1 To provide assembled union uniformity this Standard Practice establishes dimensions (Table 4 Column E) for the location of the bottom of the sockets. Socket welding union ends shall be faced at right angles to the axis to provide a flat surface against which to weld, and the socket shall be counterbored or otherwise machined to insure uniform depth and circularity.

9.2 When installing socket weld end unions, to minimize the possibility of cracking of the fillet welds, it is recommended that the connecting pipe be withdrawn approximately 0.06 inches away from the bottom of the union socket bore before welding (see Figure 2).

10. **THREADED UNIONS**

10.1 Dimensions for threaded unions are shown in Table 5. Internal pipe threads shall be NPT in accordance with ASME B1.20.1. Gaging procedures and practice shall be in accordance with Section 8 of the same standard.

11. **NUT THREADS**

11.1 Internal threads of the nut and external threads of the (Threadpiece) Female part shall be American National Thread form made in accordance with the formulae for special threads appearing in ASME B1.1, Unified and American Screw Threads, Class 2A External and 2B Internal Tolerances and Clearances.

11.2 At manufacturer's option, changes to the values in Column H are permitted, provided the requirements of ASME B1.1 and all requirements of this Standard Practice are met.

12. **FINISH**

12.1 Surfaces must be free of sharp burrs and have a workmanlike finish.

13. **TOLERANCES**

13.1 **General.** Tolerances are listed in Tables 4 and 5.

13.2 **Concentricity.** The socket shall be concentric with the waterway bore within a tolerance of plus or minus 0.03 in. for all sizes.

13.3 **Coincidence of Axis.** The maximum allowable variation in the alignment of one threaded pipe end of the assembled union to the axis of the opposite threaded pipe end shall not exceed 0.19 in. in 1 foot. Figure 1 illustrates one method that may be used to check alignment.

14. **NUT TIGHTENING TORQUE**

14.1 Recommended minimum nut tightening torque values are listed in Table 3.

15. **CORROSION PROTECTION**

15.1 Unions shall be effectively protected against corrosion. Excess oils shall be considered unacceptable as corrosion protective media. Specialty protection shall be a matter of agreement between the manufacturer and purchaser.

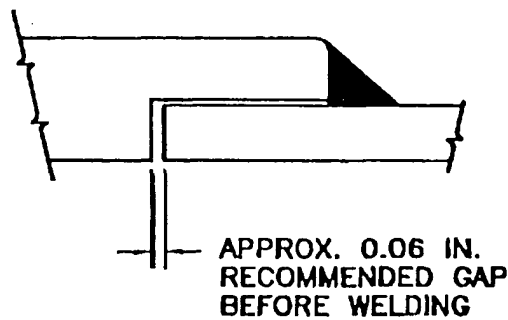
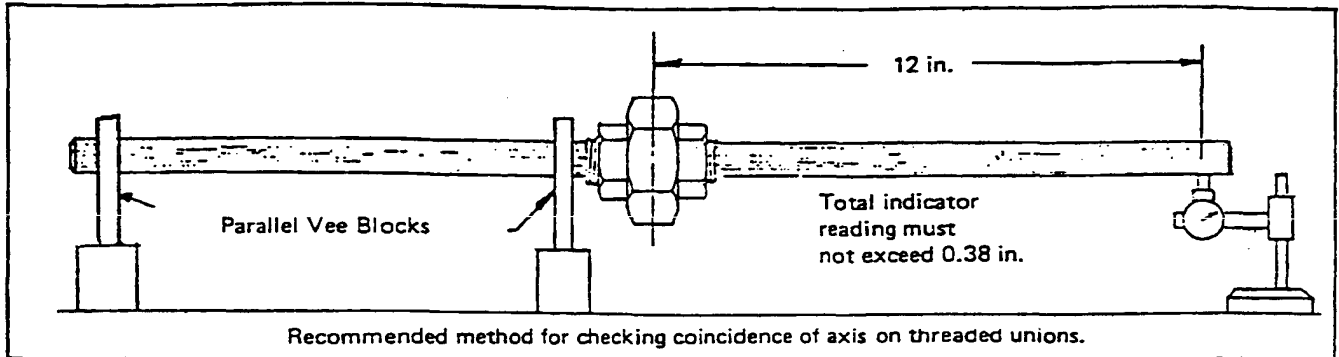

Figure 2 - Welding Gap



Illustrative Only
FIGURE 1

TABLE 3
Minimum Recommended
Nut Tightening Torque

Nominal Pipe Size	Foot Pounds (Minimum)
1/8	85
1/4	85
3/8	100
1/2	100
3/4	120
1	120
1-1/4	130
1-1/2	130
2	130
2-1/2	150
3	150

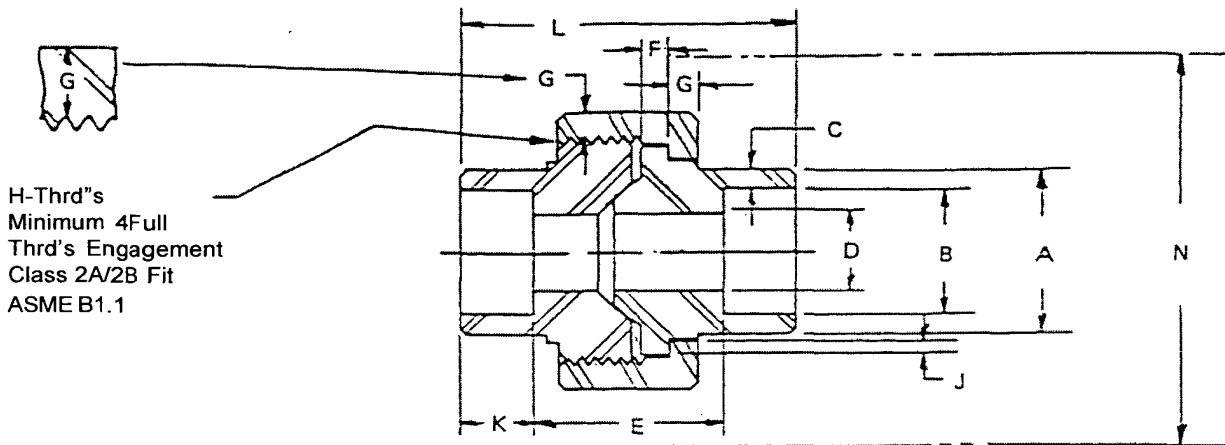

TABLE 4 - Class 3000 Carbon and Stainless Steel Pipe Unions - Socket Welding Ends

Nom. Pipe Size	Pipe End Min. A	Socket Bore Dia. B	Socket Wall Min. C	Water Way Bore (a) D	Laying Length E	Male Flange Min. F	Nut Min. G	Thrds Per Inch H	Bearing Min. J	Depth of Socket Min. K	Length Assem. Nominal L	Clear Assem. Nut N
1/8	0.86	0.440 0.420	0.125	0.299 0.239	0.88 0.75	0.125	0.125	16	0.049	0.38	1.63	2.0
1/4	0.86	0.575 0.555	0.130	0.394 0.334	0.88 0.75	0.125	0.125	16	0.049	0.38	1.63	2.0
3/8	1.02	0.710 0.690	0.138	0.523 0.463	1.06 0.81	0.135	0.135	14	0.054	0.38	1.81	2.2
1/2	1.23	0.875 0.855	0.161	0.652 0.592	1.06 0.81	0.145	0.145	14	0.059	0.38	1.93	2.3
3/4	1.46	1.085 1.065	0.168	0.854 0.794	1.25 1.00	0.160	0.160	11	0.066	0.50	2.24	2.6
1	1.79	1.350 1.330	0.196	1.079 1.019	1.35 1.03	0.180	0.175	11	0.073	0.50	2.44	3.1
1 1/4	2.16	1.695 1.675	0.208	1.410 1.350	1.60 1.28	0.210	0.205	10	0.084	0.50	2.80	3.7
1 1/2	2.42	1.935 1.915	0.218	1.640 1.580	1.66 1.34	0.230	0.220	10	0.091	0.50	3.01	4.4
2	2.96	2.426 2.406	0.238	2.097 2.037	1.79 1.47	0.260	0.250	10	0.106	0.62	3.39	5.2
2 1/2	3.61	2.931 2.906	0.302	2.529 2.409	2.43 2.05	0.295	0.280	8	0.121	0.62	4.03	5.9
3	4.30	3.560 3.535	0.327	3.128 3.008	2.51 2.11	0.325	0.315	8	0.139	0.62	4.29	6.9

NOTE: (a) The contact diameter of the male/female tailpiece is affected by the waterway bore (Col. D). The manufacturer shall consider the relationships between the contact point and waterway diameter in his design.

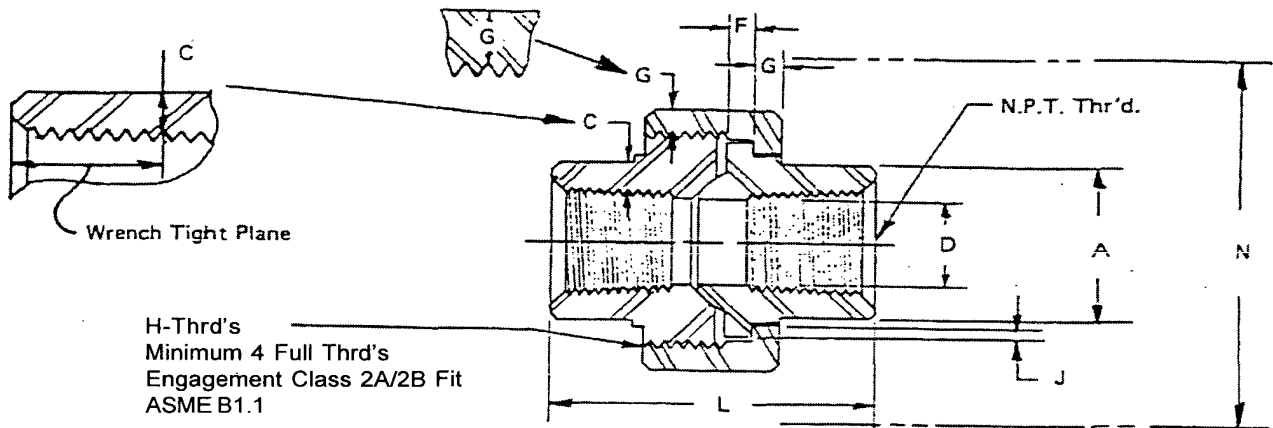

TABLE 5 - Class 3000 Carbon and Stainless Steel Pipe Unions - Threaded Ends

Nom. Pipe Size	Pipe End Min. A	Wall Min C	Water Way Bore D	Male Flange Min. F	Nut Min. G	Threads Per Inch H	Bearing Min. J	Length Assem. Nominal L	Clear Assem. Nut N
1/8	0.58	0.095	0.332 0.253	0.125	0.125	16	0.049	1.63	2.0
1/4	0.75	0.119	0.438 0.372	0.125	0.125	16	0.049	1.63	2.0
3/8	0.90	0.126	0.562 0.532	0.135	0.135	14	0.054	1.81	2.2
1/2	1.09	0.147	0.703 0.672	0.145	0.145	14	0.059	1.93	2.3
3/4	1.32	0.154	0.906 0.842	0.160	0.160	11	0.066	2.24	2.6
1	1.63	0.179	1.141 1.092	0.180	0.175	11	0.073	2.44	3.1
1 1/4	1.99	0.191	1.484 1.392	0.210	0.205	10	0.084	2.80	3.7
1 1/2	2.25	0.200	1.714 1.622	0.230	0.220	10	0.091	3.01	4.4
2	2.76	0.218	2.188 2.052	0.260	0.250	10	0.106	3.39	5.2
2 1/2	3.36	0.276	2.609 2.532	0.295	0.280	8	0.121	4.03	5.9
3	4.03	0.300	3.250 3.042	0.325	0.315	8	0.139	4.29	6.9

NOTE: (a) The contact diameter of the male/female tailpiece is affected by the waterway bore (Col. D). The manufacturer shall consider the relationships between the contact point and waterway diameter in his design.

ANNEX A
Referenced Standards and Applicable Dates

This Annex is an integral part of this Standard Practice and is placed after the main text for convenience.

Standard Name or Description.

ASME

B1.1-1989	Unified Inch Screw Threads
B1.20.1-1993 (R 1992)*	Pipe Threads, General Purpose (Inch)
B36.10M-1996	Welded and Seamless Wrought Steel Pipe

ASTM

A 105/A 105M-1998	Carbon Steel Forgings for Piping Applications
A 106-1999e1	Seamless Carbon Steel Pipe for High Temperature Service
A 234/A 234M-1999	Piping Fittings of Wrought Carbon Steel and Alloy Steel for Moderate and High Temperature Service
A 182/A 182M-1999	Forged or Rolled Alloy-Steel Pipe Flanges, Forged Fittings, and Valves and Parts for High-Temperature Service
A 403/A 403M-2000b	Wrought Austenitic Stainless Steel Pipe Fittings
A 312/A 312M-2000	Seamless and Welded Austenitic Stainless Steel Pipe

MSS

SP-25-1998	Standard Marking System for Valves, Fittings, Flanges and Unions
------------	--

*Reaffirmed

Publications of the following organizations appear in the above list:

ASME	American Society of Mechanical Engineers 3 Park Ave., New York, NY 10016-5990
ASTM	American Society for Testing and Materials 100 Barr Harbor Drive, West Conshohocken, PA 19428-2959
MSS	Manufacturers Standardization Society of The Valve and Fittings Industry, Inc. 127 Park Street, N.E., Vienna, VA 22180

List of MSS Standard Practices (Price List Available Upon Request)

Number	
SP-6-2001	Standard Finishes for Contact Faces of Pipe Flanges and Connecting-End Flanges of Valves and Fittings
SP-9-2001	Spot Facing for Bronze, Iron and Steel Flanges
SP-25-1998	Standard Marking System For Valves, Fittings, Flanges and Unions
SP-42-1999	Class 150 Corrosion Resistant Gate, Globe, Angle and Check Valves with Flanged and Butt Weld Ends
SP-43-1991	(R 01) Wrought Stainless Steel Butt-Welding Fittings
SP-44-1996	(R 01) Steel Pipeline Flanges
SP-45-1998	Bypass and Drain Connections
SP-51-2000	Class 150LW Corrosion Resistant Cast Flanges and Flanged Fittings
SP-53-1999	Quality Standard for Steel Castings and Forgings for Valves, Flanges and Fittings and Other Piping Components - Magnetic Particle Examination Method
SP-54-1999	Quality Standard for Steel Castings for Valves, Flanges, and Fittings and Other Piping Components - Radiographic Examination Method
SP-55-2001	Quality Standard for Steel Castings for Valves, Flanges, Fittings, and Other Piping Components - Visual Method for Evaluation of Surface Irregularities
SP-58-1993	Pipe Hangers and Supports - Materials, Design and Manufacture
SP-60-1999	Connecting Flange Joint Between Tapping Sleeves and Tapping Valves
SP-61-1999	Pressure Testing of Steel Valves
SP-65-1999	High Pressure Chemical Industry Flanges and Threaded Stubs for Use with Lens Gaskets
SP-67-1995	Butterfly Valves
SP-68-1997	High Pressure Butterfly Valves with Offset Design
SP-69-1996	Pipe Hangers and Supports - Selection and Application
SP-70-1998	Cast Iron Gate Valves, Flanged and Threaded Ends
SP-71-1997	Gray Iron Swing Check Valves, Flanged and Threaded Ends
SP-72-1999	Ball Valves with Flanged or Butt Welding Ends for General Service
SP-73-1991	(R 96) Brazing Joints for Wrought and Cast Copper Alloy Solder Joint Pressure Fittings
SP-75-1998	Specification for High Test Wrought Butt Welding Fittings
SP-77-1995	(R 00) Guidelines for Pipe Support Contractual Relationships
SP-78-1998	Cast Iron Plug Valves, Flanged and Threaded Ends
SP-79-1999a	Socket-Welding Reducer Inserts
SP-80-1997	Bronze Gate, Globe, Angle and Check Valves
SP-81-2001	Stainless Steel, Bonnetless, Flanged Knife Gate Valves
SP-82-1992	Valve Pressure Testing Methods
SP-83-2001	Class 3000 Steel Pipe Unions, Socket Welding and Threaded
SP-85-1994	Cast Iron Globe & Angle Valves, Flanged and Threaded Ends
SP-86-1997	Guidelines for Metric Data in Standards for Valves, Flanges, Fittings and Actuators
SP-87-1991	(R 96) Factory-Made Butt-Welding Fittings for Class 1 Nuclear Piping Applications
SP-88-1993	(R 01) Diaphragm Valves
SP-89-1998	Pipe Hangers and Supports - Fabrication and Installation Practices
SP-90-2000	Guidelines on Terminology for Pipe Hangers and Supports
SP-91-1992	(R 96) Guidelines for Manual Operations of Valves
SP-92-1999	MSS Valve User Guide
SP-93-1999	Quality Standard for Steel Castings and Forgings for Valves, Flanges, and Fittings and Other Piping Components-Liquid Penetrant Examination Method
SP-94-1999	Quality Std for Ferritic and Martensitic Steel Castings for Valves, Flanges, and Fittings and Other Piping Components-Ultrasonic Examination Method
SP-95-2000	Swage(d) Nipples and Bull Plugs
SP-96-2001	Guidelines on Terminology for Valves and Fittings
SP-97-2001	Integrally Reinforced Forged Branch Outlet Fittings-Socket Welding, Threaded, and Buttwelding Ends
SP-98-2001	Protective Coatings for the Interior of Valves, Hydrants, and Fittings
SP-99-1994	(R 01) Instrument Valves
SP-100-1997	Qualification Requirements for Elastomer Diaphragms for Nuclear Diaphragm Type Valves
SP-101-1989	(R 01) Part-Turn Valve Actuator Attachment-Flange and Driving Component Dimensions and Performance Characteristics
SP-102-1989	(R 01) Multi-Turn Valve Actuator Attachment - Flange and Driving Component Dimensions and Performance Characteristics
SP-103-1995	(R 00) Wrought Copper and Copper Alloy Insert Fittings for Polybutylene Systems
SP-104-1995	Wrought Copper Solder Joint Pressure Fittings
SP-105-1996	(R 01) Instrument Valves for Code Applications
SP-106-1990	(R 96) Cast Copper Alloy Flanges and Flanged Fittings, Class 125, 150 and 300
SP-107-1991	(R 00) Transition Union Fittings for Joining Metal and Plastic Products
SP-108-1996	Resilient-Seated Cast Iron-Eccentric Plug Valves
SP-109-1997	Welded Fabricated Copper Solder Joint Pressure Fittings
SP-110-1996	Ball Valves Threaded, Socket-Welding, Solder Joint, Grooved and Flared Ends
SP-111-2001	Gray-Iron and Ductile-Iron Tapping Sleeves
SP-112-1999	Quality Standard for Evaluation of Cast Surface Finishes - Visual and Tactile Method. This SP must be sold with a 10-surface, three dimensional Cast Surface Comparator, which is a necessary part of the Standard. Additional Comparators may be sold separately at \$25.00 each. Same quantity discounts apply on total order.
SP-113-2001	Connecting Joint between Tapping Machines and Tapping Valves
SP-114-2001	Corrosion Resistant Pipe Fittings Threaded and Socket Welding, Class 150 and 1000
SP-115-1999	Excess Flow Valves for Natural Gas Service
SP-116-1996	Service Line Valves and Fittings for Drinking Water Systems
SP-117-1996	Bellows Seals for Globe and Gate Valves
SP-118-1996	Compact Steel Globe & Check Valves - Flanged, Flangeless, Threaded & Welding Ends (Chemical & Petroleum Refinery Service)
SP-119-1996	Belled End Socket Welding Fittings, Stainless Steel and Copper Nickel
SP-120-1997	Flexible Graphite Packing System for Rising Stem Steel Valves (Design Requirements)
SP-121-1997	Qualification Testing Methods for Stem Packing for Rising Stem Steel Valves
SP-122-1997	Plastic Industrial Ball Valves
SP-123-1998	Non-Ferrous Threaded and Solder-Joint Unions for Use With Copper Water Tube
SP-124-2001	Fabricated Tapping Sleeves
SP-125-2000	Gray Iron and Ductile Iron In-Line, Spring-Loaded, Center-Guided Check Valves
SP-126-2000	Steel In-Line Spring-Assisted Center Guided Check Valves
SP-127-2001	Bracing for Piping Systems Seismic-Wind-Dynamic Design, Selection, Application
(R YEAR)	Indicates year standard reaffirmed without substantive changes

A large number of former MSS Practices have been approved by the ANSI or ANSI Standards, published by others. In order to maintain a single source of authoritative information, the MSS withdraws its Standard Practice in such cases.

Manufacturers Standardization Society of the Valve and Fittings Industry, Inc.
127 Park Street, N.E., Vienna, VA 22180-4620 • (703) 281-6613 Fax # (703) 281-6671