

ASME B16.36-2009
(Revision of ASME B16.36-2006)

Orifice Flanges

AN AMERICAN NATIONAL STANDARD



The American Society of
Mechanical Engineers



Date of Issuance: November 4, 2009

The next edition of this Standard is scheduled for publication in 2014. There will be no addenda issued to this edition.

ASME issues written replies to inquiries concerning interpretations of technical aspects of this Standard. Interpretations and errata are published on the ASME Web site under the Committee Pages at <http://cstools.asme.org> as they are issued.

ASME is the registered trademark of The American Society of Mechanical Engineers.

This code or standard was developed under procedures accredited as meeting the criteria for American National Standards. The Standards Committee that approved the code or standard was balanced to assure that individuals from competent and concerned interests have had an opportunity to participate. The proposed code or standard was made available for public review and comment that provides an opportunity for additional public input from industry, academia, regulatory agencies, and the public-at-large.

ASME does not “approve,” “rate,” or “endorse” any item, construction, proprietary device, or activity.

ASME does not take any position with respect to the validity of any patent rights asserted in connection with any items mentioned in this document, and does not undertake to insure anyone utilizing a standard against liability for infringement of any applicable letters patent, nor assume any such liability. Users of a code or standard are expressly advised that determination of the validity of any such patent rights, and the risk of infringement of such rights, is entirely their own responsibility.

Participation by federal agency representative(s) or person(s) affiliated with industry is not to be interpreted as government or industry endorsement of this code or standard.

ASME accepts responsibility for only those interpretations of this document issued in accordance with the established ASME procedures and policies, which precludes the issuance of interpretations by individuals.

No part of this document may be reproduced in any form,
in an electronic retrieval system or otherwise,
without the prior written permission of the publisher.

The American Society of Mechanical Engineers
Three Park Avenue, New York, NY 10016-5990

Copyright © 2009 by
THE AMERICAN SOCIETY OF MECHANICAL ENGINEERS
All rights reserved
Printed in U.S.A.

CONTENTS

Foreword	iv
Committee Roster	v
Correspondence With the B16 Committee	vi
1 Scope	1
2 General	1
3 Pressure–Temperature Ratings	1
4 Material	1
5 Size	2
6 Marking	2
7 Flange Facing Finish	2
8 Gaskets for Raised Face Flanges	2
9 Pressure Taps	2
10 Jack Screw Provision	2
11 Flange Dimensions	3
12 Flange Threads	3
13 Tolerances	3
Figures	
1 Corner Taps	9
2 Angular Meter Tap for RTJ Flanges	9
3 Jack Bolts	9
Tables	
1 Class 300 Orifice Flanges, Welding Neck, Threaded, and Slip-On	4
2 Class 600 Orifice Flanges, Welding Neck	5
3 Class 900 Orifice Flanges, Welding Neck	6
4 Class 1500 Orifice Flanges, Welding Neck	7
5 Class 2500 Orifice Flanges, Welding Neck	8
Mandatory Appendices	
I Dimensional Data for Classes 300, 600, 900, 1500, and 2500 Flanges in U.S. Customary Units	11
II Dimensional Data for Class 400 Flanges in U.S. Customary Units	17
III References	19
Nonmandatory Appendix	
A Quality System Program	20

FOREWORD

August of 1956 marked the first recorded correspondence noting the lack of standardization for orifice flanges. There were, and still are, several codes for the performance and calibration of orifice flanges, but there had been no standardization of the flanges themselves. Over the ensuing 3 years, correspondence continued among the Instrument Society of America, American Gas Association, and the B16 Standards Committee.

On December 3, 1959, Subcommittee 3 (now Subcommittee C) of B16 authorized the appointment of a Task Force to undertake drafting of a standard. Although the initial work progressed smoothly, a controversy developed over the standard size of taps to be specified for the flanges. This required many years to resolve. It was finally achieved in 1973 with the issuance of a draft from the Task Force. Comments and objections to this draft from members of Subcommittee C were resolved, and a redraft was approved by the Subcommittee late in 1974. The B16 Standards Committee was balloted in the spring of 1975 and approval was gained. Comments from B16 members from the gas industry requested that the Class 400 orifice flange be included, and the B16 Subcommittee C agreed to consider this for a possible addendum. The Standard was approved by ANSI on August 15, 1975.

On April 30, 1979, an addenda was issued, which added Class 400 flanges and Mandatory Appendix II covering reference documents and organizations.

In 1982, American National Standards Committee B16 was reorganized as an ASME Committee operating under procedures accredited by ANSI. In the 1988 edition, figures were added to illustrate jack bolts and corner taps, metric units have been omitted, and references to other standards have been updated. Following approval by the B16 Main Committee and the ASME Supervisory Board, the Standard was approved as an American National Standard by ANSI on February 18, 1988.

In 1996, several revisions were made, including the addition of angular meter taps for ring joint flanges in sizes not previously covered. Following approval by the B16 Main Committee and the ASME Supervisory Board, the Standard was approved as an American National Standard by ANSI on November 6, 1996.

In 2006, several revisions were made, including the use of metric units as the primary reference units, while maintaining U.S. Customary units in either parenthetical or separate forms. Changes to dimensions and nomenclature followed that were contained within the 2003 edition of ASME B16.5. This includes the change of minimum flange thickness from C to t_f and corrections for Y_1 and Y_2 . Class 400 remains in U.S. Customary tables in Mandatory Appendix II, but is not given in the metric dimensional tables. There are numerous requirement clarifications and editorial revisions. Following the approvals of the Standards Committee and ASME, approval for the new edition was granted by the American National Standards Institute on November 6, 2006.

In the 2009 edition, Mandatory Appendix III was revised and updated. Also, section 4, the materials section, has been revised to cover requirements of material specification editions other than those listed in Appendix III of ASME B16.5.

Requests for interpretations or suggestions for revisions should be sent to the Secretary, B16 Committee, Three Park Avenue, New York, NY 10016-5990. As an alternative, inquiries may be submitted via e-mail to: SecretaryB16@asme.org.

This revision was approved by the American National Standards Institute on August 13, 2009.

ASME B16 COMMITTEE

Standardization of Valves, Flanges, Fittings, and Gaskets

(The following is the roster of the Committee at the time of approval of this Standard.)

STANDARDS COMMITTEE OFFICERS

W. B. Bedesem, *Chair*
M. L. Nayyar, *Vice Chair*
D. R. Sharp, *Secretary*

STANDARDS COMMITTEE PERSONNEL

R. W. Barnes , ANRIC Enterprises, Inc.	G. A. Jolly , Vogt Valves/Flowserve
W. B. Bedesem , ExxonMobil Research & Engineering Co.	M. Katcher , Haynes International
D. F. Buccicone , Elkhart Products Corp.	W. N. McLean , B & L Engineering
A. M. Cheta , Shell Westhollow Technology Center	T. A. McMahon , Fisher Controls International, Inc.
M. A. Clark , NIBCO, Inc.	M. L. Nayyar , Bechtel Power Corp.
G. A. Cuccio , Capital Manufacturing Co.	J. D. Page , U.S. Nuclear Regulatory Commission
C. E. Davila , Crane Valves	W. H. Patrick , The Dow Chemical Co.
C. E. Floren , Mueller Co.	R. A. Schmidt , Hackney Ladish, Inc.
D. R. Frikken , Becht Engineering Co.	D. R. Sharp , The American Society of Mechanical Engineers
R. P. Griffiths , U.S. Coast Guard	H. R. Sonderegger , Anvil International, Inc.
M. L. Henderson , TIEC, Inc.	W. M. Stephan , Flexitallic LP
	D. A. Williams , Southern Company Services

SUBCOMMITTEE C — STEEL FLANGES AND FLANGED FITTINGS

C. E. Davila , <i>Chair</i> , Crane Valves	C. L. Henley , Black & Veatch
A. P. Maslowski , <i>Secretary</i> , The American Society of Mechanical Engineers	R. E. Johnson , Consultant
A. Appleton , Alloy Stainless Products Co., Inc.	M. Katcher , Haynes International
W. B. Bedesem , ExxonMobil Research & Engineering Co.	W. N. McLean , B & L Engineering
A. M. Cheta , Shell Westhollow Technology Center	M. L. Nayyar , Bechtel Power Corp.
B. Dennis , Kerkau Manufacturing	W. H. Patrick , The Dow Chemical Co.
J. P. Ellenberger , Consultant	T. V. Ramakrishnan , Forged Vessel Connections
D. R. Frikken , Becht Engineering Co.	R. A. Schmidt , Hackney Ladish, Inc.
M. L. Henderson , TIEC, Inc.	J. P. Tucker , Flowserve
	M. M. Zaidi , Jacobs

CORRESPONDENCE WITH THE B16 COMMITTEE

General. ASME Standards are developed and maintained with the intent to represent the consensus of concerned interests. As such, users of this Standard may interact with the Committee by requesting interpretations, proposing revisions, and attending Committee meetings. Correspondence should be addressed to:

Secretary, B16 Standards Committee
The American Society of Mechanical Engineers
Three Park Avenue
New York, NY 10016-5990

As an alternative, inquiries may be submitted via e-mail to: SecretaryB16@asme.org.

Proposing Revisions. Revisions are made periodically to the Standard to incorporate changes that appear necessary or desirable, as demonstrated by the experience gained from the application of the Standard. Approved revisions will be published periodically.

The Committee welcomes proposals for revisions to this Standard. Such proposals should be as specific as possible, citing the paragraph number(s), the proposed wording, and a detailed description of the reasons for the proposal, including any pertinent documentation.

Interpretations. Upon request, the B16 Committee will render an interpretation of any requirement of the Standard. Interpretations can only be rendered in response to a written request sent to the Secretary of the B16 Standards Committee.

The request for interpretation should be clear and unambiguous. It is further recommended that the inquirer submit his/her request in the following format:

Subject: Cite the applicable paragraph number(s) and the topic of the inquiry.
Edition: Cite the applicable edition of the Standard for which the interpretation is being requested.
Question: Phrase the question as a request for an interpretation of a specific requirement suitable for general understanding and use, not as a request for an approval of a proprietary design or situation. The inquirer may also include any plans or drawings, which are necessary to explain the question; however, they should not contain proprietary names or information.

Requests that are not in this format will be rewritten in this format by the Committee prior to being answered, which may inadvertently change the intent of the original request.

ASME procedures provide for reconsideration of any interpretation when or if additional information that might affect an interpretation is available. Further, persons aggrieved by an interpretation may appeal to the cognizant ASME Committee or Subcommittee. ASME does not "approve," "certify," "rate," or "endorse" any item, construction, proprietary device, or activity.

Attending Committee Meetings. The B16 Standards Committee regularly holds meetings, which are open to the public. Persons wishing to attend any meeting should contact the Secretary of the B16 Standards Committee.

ORIFICE FLANGES

1 SCOPE

This Standard covers flanges (similar to those covered in ASME B16.5) that have orifice pressure differential connections. Coverage is limited to the following:

(a) welding neck flanges Classes 300, 600, 900, 1500, and 2500. U.S. Customary units are presented in Mandatory Appendix I.

(b) slip-on and threaded Class 300.

(c) welding neck flanges Class 400 in U.S. Customary units in Mandatory Appendix II.

2 GENERAL

2.1 References

Codes, standards, and specifications containing provisions to the extent referenced herein constitute requirements of this Standard. These reference documents are listed in Mandatory Appendix III.

2.2 Quality Systems

Nonmandatory requirements relating to the product manufacturer's Quality System Program are described in Nonmandatory Appendix A.

2.3 Relevant Units

This Standard states values in both metric and U.S. Customary units. As an exception, diameter of bolts and flange bolt holes are expressed in inch units only. These systems of units are to be regarded separately as standard. Within the text, the U.S. Customary units are shown in parentheses or in separate tables. The values stated in each system are not exact equivalents; therefore, it is required that each system of units be used independently of the other. Except for diameter of bolts and flange bolt holes, combining values from the two systems constitutes nonconformance with the standard. Except for Class 400, the values in U.S. Customary units are in Mandatory Appendix I. The main text of this Standard does not contain requirements for Class 400 welding neck flanges; however, Mandatory Appendix II does contain requirements for this class, expressed in U.S. Customary units only.

2.4 Convention

For the purposes of determining conformance with this Standard, the convention for fixing significant digits where limits and maximum and minimum values are

specified, shall be rounded as defined in ASTM Practice E 29. This requires that an observed or calculated value shall be rounded off to the nearest unit in the last right-hand digit used for expressing the limit. Decimal values and tolerances do not imply a particular method of measurement.

2.5 Denotation

2.5.1 Pressure Rating Designation

(a) Class, followed by a dimensionless number, is the designation for pressure-temperature ratings as follows: Classes 300 600 900 1500 2500.

(b) Class 400 is retained in the U.S. Customary tables.

2.5.2 Sizes. NPS, followed by a dimensionless number, is the designation for the nominal flange size. NPS is related to the reference nominal diameter, DN, used in international standards. The relationship is, typically, as follows:

NPS	DN
1	25
1½	40
2	50
2½	65
3	80
4	100

GENERAL NOTE: For NPS ≥ 4, the related DN = 25 (NPS).

2.6 Service Conditions

Criteria for selection of materials suitable for the particular fluid service are not within the scope of this Standard.

3 PRESSURE-TEMPERATURE RATINGS

The pressure-temperature ratings, including all use recommendations and limitations, and the method of rating given in ASME B16.5 apply to these flanges.

4 MATERIAL

4.1 General

Flange materials shall be in accordance with the requirements of ASME B16.5. For materials manufactured to editions of the material specification other than those listed in Appendix III of ASME B16.5, refer to para. 4.3.

4.2 Bolting

Bolting material recommendations are given in ASME B16.5. For materials manufactured to editions of the material specification other than those listed in Appendix III of ASME B16.5, refer to para. 4.3.

4.3 Materials Manufactured to Other Editions

Materials may meet the requirements of material specification editions other than those listed in Appendix III of ASME B16.5, provided

(a) the materials are the same specification, e.g., grade, type, class, or alloy, and heat-treated conditions, as applicable

(b) the flange manufacturer certifies that the requirements of the edition of the specification listed in Appendix III of ASME B16.5 have been met

4.4 Plugs

Pressure-retaining plugs shall conform to ASME B16.11, unless otherwise agreed between purchaser and manufacturer. Plug material shall be at least as corrosion resistant as the corresponding flange material.

5 SIZE

Orifice flange sizes are indicated by the nominal pipe size to which they are attached. Only those listed in Tables 1 through 5, Tables I-1 through I-5, and Mandatory Appendix II are considered standard.

6 MARKING

Flanges shall be marked as required in ASME B16.5. For welding neck flanges only, the bore diameter shall be marked.

7 FLANGE FACING FINISH

The finish of contact faces shall conform to the requirements of ASME B16.5.

8 GASKETS FOR RAISED FACE FLANGES

8.1 Gasket Thickness

Flange dimensions are based on the use of 1.5 mm (0.06 in.) thick gaskets.

8.2 Flange Gaskets Requiring Dimensional Changes

When the location of the pressure tap with respect to the orifice plate is critical to the service and metering conditions, its location may be altered to accommodate other than 1.5 mm (0.06 in.) thick gaskets or ring-type joint gaskets whose thickness may vary from that listed in Tables 2, 3, 4, and 5 or those listed in Tables I-2, I-3, I-4, and I-5 or Mandatory Appendix II.

The alteration of location may also be accomplished by the removal of 2 mm (0.06 in.) from the raised face of the flange. If an original 2 mm (0.06 in.) high raised face is removed, the user is cautioned to limit the outside diameter of the gasket or orifice plate to the tabulated R dimension.

9 PRESSURE TAPS

9.1 General

Each orifice flange shall be provided with two pressure tap holes extending radially from the outside diameter of the flange to the inside diameter of the flange. Corner taps may be used on NPS 1½ and smaller if space permits. See Fig. 1.

For ring joint flanges listed in Tables 2 through 5, Tables I-1 through I-5, and Mandatory Appendix II, where radial taps will interfere with the ring groove, angular meter taps, as illustrated in Fig. 2, will be required. Each pressure tap hole shall be equipped with a pipe plug.

9.2 Location

9.2.1 Measurement. The 24 mm (0.94 in.) dimension for raised face and 19 mm (0.75 in.) for ring joint shall be measured at the bore.

9.2.2 Identification. For ring joint flanges requiring alteration of pressure tap location due to interference with the ring groove other than methods provided in this Standard, such alteration shall be identified per agreement between purchaser and manufacturer.

9.3 Pipe Connection

Unless otherwise specified, pressure tap holes may be either tapped ½ NPT in accordance with ASME B1.20.1 or ½ NPS socket connection in accordance with ASME B16.11.

10 JACK SCREW PROVISION

10.1 Location

Each flange shall have a machine bolt mounted in a hole drilled on the flange bolt circle centerline at 90 deg from the pressure taps, for use as a jack screw. The machine bolt shall be regular with one heavy hex nut. See Fig. 3.

10.2 Slot for Nut

A slot shall be provided in the flange 2 mm (0.06 in.) wider than the width across flats of the nut. The depth of the slot shall admit the nut so that there is no interference with the joining of the flanges when bolted together without orifice plate.

10.3 Tapped Hole

As an alternative to para. 10.2, a tapped hole may be provided and the hex nut omitted when agreed on between the purchaser and the manufacturer.

11 FLANGE DIMENSIONS

Dimensions are listed in Tables 1, 2, 3, 4, and 5 for metric, and Tables I-1, I-2, I-3, I-4, and I-5, and Mandatory Appendix II for U.S. Customary.

12 FLANGE THREADS

Threaded flanges shall have an American National Standard taper pipe thread conforming to ASME B1.20.1.

(a) The thread shall be concentric with the axis of the flange. Variations in alignment shall not exceed 5 mm/m (0.06 in./ft).

(b) The flanges are made with counterbores at the back of the flange and the threads shall be chamfered to the diameter of the counterbore at an angle of approximately 45 deg with the axis of the thread to afford easy entrance in making a joint. The counterbore and chamfer shall be concentric with the thread.

(c) In order to permit the pipe to be inserted to the face of the flange, the threads should have full root

diameters through to the face of the flange, or shall have a counterbore at the face of the flange.

(d) The gaging notch of the working gage shall come flush with the bottom of the chamfer in all threaded flanges and shall be considered as being the intersection of the chamfer cone and the pitch cone of the thread. This depth of chamfer is approximately equal to one-half the pitch of the thread.

(e) The maximum allowable thread variation is one turn large or small from the gaging notch.

13 TOLERANCES

Tolerances on all dimensions shall be as shown in ASME B16.5 except for those shown below.

13.1 Pressure Tap Location

Tolerance on location of center of pressure tap hole¹ from flange face shall be

(a) ± 0.5 mm (± 0.02 in.) for flanges smaller than NPS 4

(b) ± 0.8 mm (± 0.03 in.) for flanges NPS 4 and larger

13.2 Bore Diameter

Bore diameter tolerance (welding neck flanges only) is $\pm 0.5\%$ of nominal value.

¹ See para. 9.2.

Table 1 Class 300 Orifice Flanges, Welding Neck, Threaded, and Slip-On

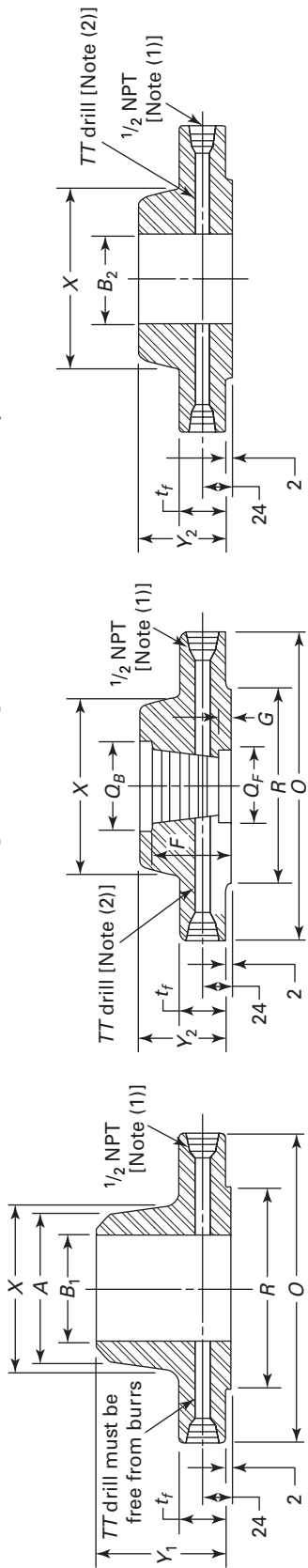

Nominal Pipe Size	Outside Diameter of Raised Face, R	Minimum Thickness of Flange, t_f	Length Through Hub Slip-On and Threaded, Y_2	Weld Neck, Y_1	Hub Diameter Beginning of Chamfer (W.N.), A	Diameter of Counterbore		Counterbore Depth (From Face)		Bore		Diameter of Pressure Connection, TT	Drilling Template		Bolt Length [(3), (4)]		
						Back, Q_B	Face, Q_F	F	G	Slip-On, B_2	Neck, B_1		Number of Holes	Diameter of Holes		Bolt Circle	of Bolts
1	50.8	36.6	46	81	33.4	35.8	33.0	36.5	19.0	34.5	(5)	6.4	88.9	4	1 1/16	5/8	115
1 1/2	73.0	36.6	46	84	48.3	50.5	48.0	37.3	18.3	49.5	(5)	6.4	114.3	4	1 3/16	3/4	120
2	92.1	36.6	48	84	60.3	63.5	59.9	38.1	17.5	61.9	(5)	6.4	127.0	8	1 1/16	5/8	115
2 1/2	104.8	36.6	49	87	73.0	76.2	72.1	44.4	14.3	74.6	(5)	6.4	149.2	8	1 3/16	3/4	120
3	127.0	36.6	51	87	88.9	92.2	87.9	46.0	14.3	90.7	(5)	9.5	168.3	8	1 3/16	3/4	120
4	157.2	36.6	52	90	114.3	117.6	113.0	47.6	14.3	116.1	(5)	12.7	200.0	8	1 3/16	3/4	120
6	215.9	32.0	52	98	168.3	171.4	166.9	47.6	7.9	170.7	(5)	12.7	269.9	12	7/8	1/2	120
8	269.9	39.7	60	110	219.1	222.2	217.2	55.6	11.1	221.5	(5)	12.7	330.2	12	1	7/8	125
10	323.8	44.5	65	116	273.0	(6)	(6)	(6)	(6)	276.2	(5)	12.7	387.4	16	1 1/8	1	145
12	381.0	49.3	71	129	323.8	(6)	(6)	(6)	(6)	327.0	(5)	12.7	450.8	16	1 1/4	1 1/8	160
14	412.8	52.4	75	141	355.6	(6)	(6)	(6)	(6)	359.2	(5)	12.7	514.4	20	1 1/4	1 1/8	165
16	469.9	65.0	81	144	406.4	(6)	(6)	(6)	(6)	410.5	(5)	12.7	571.5	20	1 3/8	1 1/4	180
18	533.4	71.0	87	157	457.0	(6)	(6)	(6)	(6)	461.8	(5)	12.7	628.6	24	1 3/8	1 1/4	185
20	584.2	77.5	94	160	508.0	(6)	(6)	(6)	(6)	513.1	(5)	12.7	685.8	24	1 3/8	1 1/4	190
24	692.2	91.5	105	167	610.0	(6)	(6)	(6)	(6)	616.0	(5)	12.7	812.8	24	1 3/8	1 1/2	210

GENERAL NOTES:

- (a) Dimensions are in millimeters, except for bolts and bolt holes. Reference Mandatory Appendix I for U.S. Customary.
 - (b) Weld neck flanges NPS 3 and smaller are dimensionally identical to Class 600 flanges and may be so marked.
 - (c) All other dimensions are in accordance with ASME B16.5.
- NOTES:**
- (1) Other NPT sizes may be furnished if required.
 - (2) For slip-on and threaded flanges, verify that TT drilling extends to inside diameter of pipe after assembly and is free from burrs.
 - (3) Bolt lengths include allowance for orifice and gasket thickness of 6 mm (0.25 in.) for NPS 1 to NPS 12 and 10 mm (0.38 in.) for NPS 14 to NPS 24.
 - (4) In conformance with ASME B16.5, stud bolt lengths do not include point heights.
 - (5) Bore diameter of weld neck flanges is to be specified by the purchaser.
 - (6) Threaded flanges are furnished in NPS 1 to NPS 8 only.

Table 3 Class 900 Orifice Flanges, Welding Neck

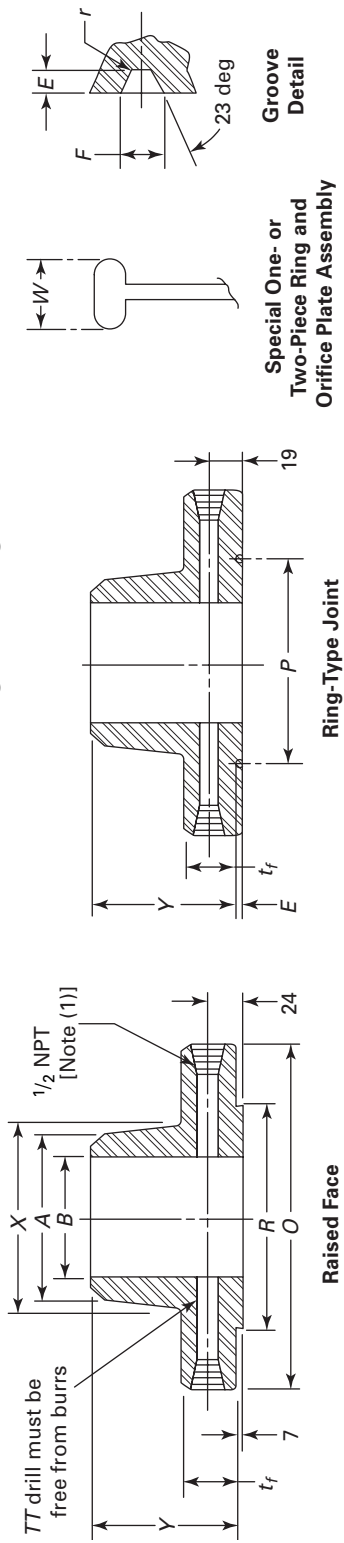

Nominal Pipe Size	Outside Diameter of Raised Face, R	Outside Diameter of Flange, O	Minimum Thickness of Flange, t _f	Length Through Hub, Y	Ring-Type Joint				Hub Diameter Beginning of Chamfer, A	Bore, B	Diameter of Connection, TT	Drilling Template		Length of Stud Bolts [(2), (3)]						
					Groove Diameter, P	Pitch Diameter, P	Groove Depth, E	Groove Width, F				Radius at Bottom, r	Special Oval Ring Height, W		Diameter of Hub, X	Diameter of Bolt Circle, TT	Number of Holes	Diameter of Holes		
1																				
1½																				
2																				
2½																				
3	127.0	240	38.1	102	R31	123.83	7.92	11.91	0.8	27.0	127	88.9	(4)	9.5	190.5	8	1	7/8	150	165
4	157.2	290	44.5	114	R37	149.23	7.92	11.91	0.8	27.0	159	114.3	(4)	12.7	235.0	8	1¼	1⅛	180	190
6	215.9	380	55.6	140	R45	211.12	7.92	11.91	0.8	27.0	235	168.3	(4)	12.7	317.5	12	1¼	1⅛	195	210
8	269.9	470	63.5	162	R49	269.88	7.92	11.91	0.8	27.0	298	219.1	(4)	12.7	393.7	12	1½	1⅝	230	240
10	323.8	545	69.9	184	R53	323.85	7.92	11.91	0.8	27.0	368	273.0	(4)	12.7	469.9	16	1½	1⅝	240	255
12	381.0	610	79.4	200	R57	381.00	7.92	11.91	0.8	27.0	419	323.8	(4)	12.7	533.4	20	1½	1⅝	260	275
14	412.8	640	85.8	213	R62	419.10	11.13	16.66	1.5	33.3	451	355.6	(4)	12.7	558.8	20	1½	1⅝	280	290
16	469.9	705	88.9	216	R66	469.90	11.13	16.66	1.5	36.5	508	406.4	(4)	12.7	616.0	20	1¾	1⅝	290	305
18	533.4	785	101.6	229	R70	533.40	12.70	19.84	1.5	39.7	565	457.2	(4)	12.7	685.8	20	2	1⅞	330	350
20	584.2	855	108.0	248	R74	584.20	12.70	19.84	1.5	39.7	622	508.0	(4)	12.7	749.3	20	2⅛	2	355	375
24	692.2	1 040	139.7	292	R78	692.15	15.88	26.97	2.4	47.6	749	609.6	(4)	12.7	901.7	20	2⅝	2½	445	470

For NPS 2½ and smaller, use Class 1500.

GENERAL NOTES:

- (a) Dimensions are in millimeters, except for bolts and bolt holes. Reference Mandatory Appendix I for U.S. Customary.
- (b) All other dimensions are in accordance with ASME B16.5.
- (c) Ring joint flanges larger than NPS 12 will require angular meter taps as shown in Fig. 2.

NOTES:

- (1) Other NPT sizes may be furnished if required.
- (2) In conformance with ASME B16.5, stud bolt lengths do not include point heights.
- (3) Bolt lengths for raised face flanges include allowance for orifice and gasket thickness of 6 mm (0.25 in.) for NPS 3 to NPS 12 and 10 mm (0.38 in.) for NPS 14 to NPS 24. Bolt lengths for ring-type joint flanges include allowance of 15 mm (0.62 in.) for NPS 3 to NPS 10 and 19 mm (0.75 in.) for NPS 12.
- (4) Bore is to be specified by the purchaser.

Table 5 Class 2500 Orifice Flanges, Welding Neck

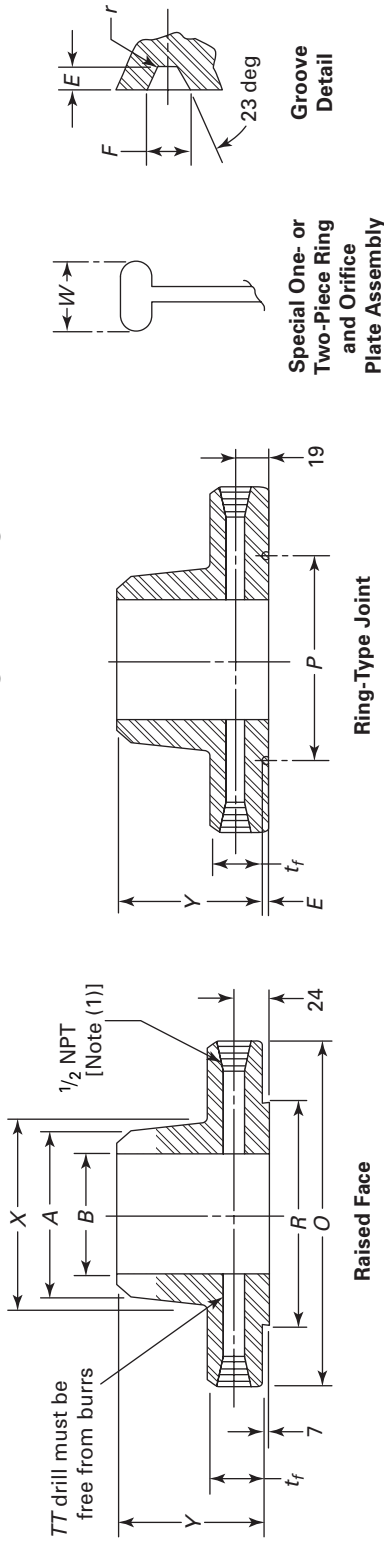

Nominal Pipe Size	Outside Diameter of Raised Face, R	Outside Diameter of Flange, O	Minimum Thickness of Flange, t _f	Length Through Hub, Y	Groove Number	Pitch Diameter, P	Groove Depth, E	Groove Width, F	Radius at Bottom, r	Ring-Type Joint			Hub Diameter Beginning of Chamfer, A	Diameter of Connection, TT	Drilling Template		Length of Stud Bolts [(2), (3)]
										Special Ring Height, W	Diameter of Hub, X	Bore, B			Diameter of Hole	Number of Holes	
1	50.8	160	38.1	92	R18	60.33	6.35	8.74	0.8	25.4	57	33.5	6.4	4	1	7/8	150
1 1/2	73.0	205	44.5	111	R23	82.55	7.92	11.91	0.8	27.0	79	48.3	6.4	4	1 1/4	1 1/8	180
2	92.1	235	50.8	127	R26	101.60	7.92	11.91	0.8	27.0	95	60.3	6.4	8	1 1/8	1	185
2 1/2	104.8	265	57.2	143	R28	111.13	9.53	13.49	1.5	30.2	114	73.0	6.4	8	1 1/4	1 1/8	205
3	127.0	305	66.7	168	R32	127.00	9.53	13.49	1.5	30.2	133	88.9	9.5	8	1 3/8	1 1/4	230
4	157.2	355	76.2	190	R38	157.18	11.13	16.66	1.5	33.3	165	114.3	12.7	8	1 5/8	1 1/2	260
6	215.9	485	108.0	273	R47	228.60	12.70	19.84	1.5	36.5	235	168.3	12.7	8	2 1/8	2	350
8	269.9	550	127.0	318	R51	279.40	14.27	23.01	1.5	39.7	305	219.1	12.7	12	2 1/8	2	385
10	323.8	675	165.1	419	R55	342.90	17.48	30.18	2.4	47.6	375	273.0	12.7	12	2 5/8	2 1/2	490
12	381.0	760	184.2	464	R60	406.40	17.48	33.32	2.4	50.8	441	323.8	12.7	12	2 7/8	2 3/4	540

GENERAL NOTES:

- (a) Dimensions are in millimeters, except for bolts and bolt holes.
 - (b) All other dimensions are in accordance with ASME B16.5.
 - (c) Ring joint flanges larger than NPS 3 will require angular meter taps as shown in Fig. 2.
- NOTES:
- (1) Other NPT sizes may be furnished if required.
 - (2) In conformance with ASME B16.5, stud bolt lengths do not include point heights.
 - (3) Bolt lengths for raised face flanges include allowance for orifice and gasket thickness of 6 mm (0.25 in.) for NPS 1 to NPS 12. Bolt lengths for ring-type joint flanges include allowance of 15 mm (0.62 in.) for NPS 1 to NPS 3.
 - (4) Bore is to be specified by the purchaser.

Fig. 1 Corner Taps

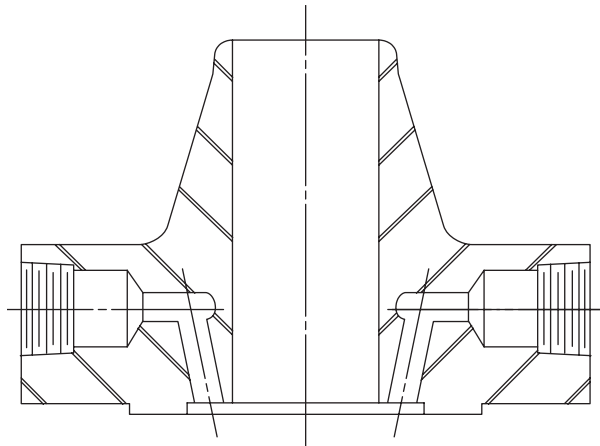

Fig. 2 Angular Meter Tap for RTJ Flanges

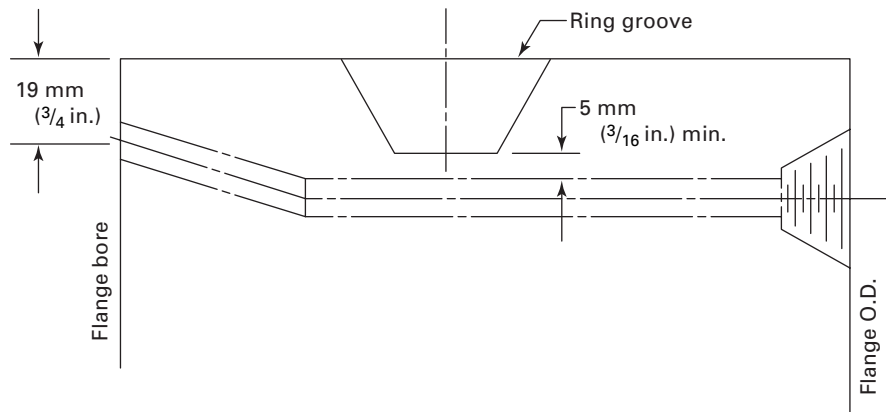
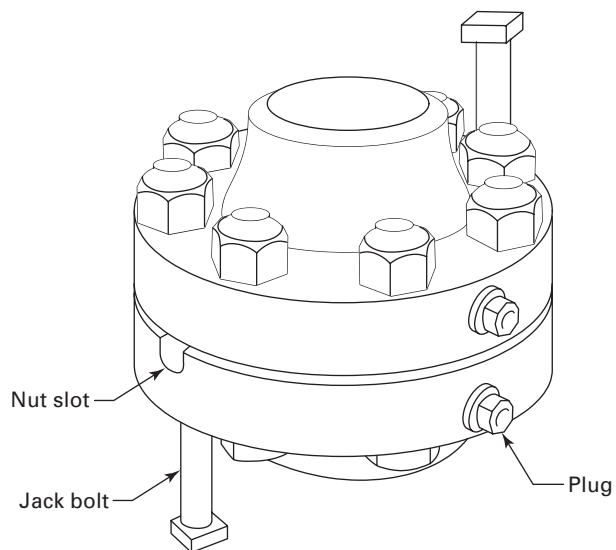

Fig. 3 Jack Bolts



INTENTIONALLY LEFT BLANK

MANDATORY APPENDIX I

DIMENSIONAL DATA FOR CLASSES 300, 600, 900, 1500, AND 2500 FLANGES IN U.S. CUSTOMARY UNITS

This Appendix is an integral part of ASME B16.36-2009, and it is placed after the main text for convenience. Tables I-1 through I-5, included in this Appendix, provide dimensional data in U.S. Customary units for the following: Classes 300, 600, 900, 1500, and 2500 flanges.

Table I-1 Class 300 Orifice Flanges, Welding Neck, Threaded, and Slip-On

Nominal Pipe Size	Outside Diameter of Raised Face, R	Minimum Thickness of Flange, t_f	Length Through Hub Slip-On and Threaded, Y_2	Hub Diameter Beginning of Chamfer (W.N.), A	Counterbore		Bore		Diameter of Pressure Connection, TT	Drilling Template		Bolt Length [(3), (4)]					
					Diameter of Back, Q_B	Face, Q_F	Slip-On, B_2	Neck, B_1		Number of Holes	Diameter of Holes		Bolt Circle	of Stud Bolts			
1	2.00	1.44	1.81	1.32	1.41	1.30	1.44	0.75	1.36	1/4	4	1 1/16	3.50	4	5/8	4.50	5.00
1 1/2	2.88	1.44	1.81	1.90	1.99	1.89	1.47	0.72	1.95	1/4	4	1 3/16	4.50	4	3/4	4.75	5.25
2	3.62	1.44	1.88	2.38	2.50	2.36	1.50	0.69	2.44	1/4	8	1 1/16	5.00	8	5/8	4.50	5.00
2 1/2	4.12	1.44	1.94	2.88	3.00	2.84	1.75	0.56	2.94	1/4	8	1 3/16	5.88	8	3/4	4.75	5.25
3	5.00	1.44	2.00	3.44	3.63	3.46	1.81	0.56	3.57	3/8	8	1 3/16	6.62	8	3/4	4.75	5.25
4	6.19	1.44	2.06	4.50	4.63	4.45	1.88	0.56	4.57	1/2	8	1 3/16	7.88	8	3/4	4.75	5.25
6	8.50	1.44	2.06	6.63	6.75	6.57	1.88	0.31	6.72	1/2	12	7/8	10.62	12	3/4	4.75	5.25
8	10.62	1.56	2.38	8.63	8.75	8.55	2.19	0.44	8.72	1/2	12	1	13.00	12	7/8	5.00	5.75
10	12.75	1.81	2.56	10.75	(6)	(6)	(6)	(6)	10.88	1/2	16	1 1/8	15.25	16	1	5.75	6.50
12	15.00	1.94	2.81	12.75	(6)	(6)	(6)	(6)	12.88	1/2	16	1 1/4	17.75	16	1 1/8	6.25	7.00
14	16.25	2.06	2.94	14.00	(6)	(6)	(6)	(6)	14.14	1/2	20	1 1/4	20.25	20	1 1/4	6.50	7.25
16	18.50	2.19	3.19	16.00	(6)	(6)	(6)	(6)	16.16	1/2	20	1 3/8	22.50	20	1 1/4	7.00	7.75
18	21.00	2.31	3.44	18.00	(6)	(6)	(6)	(6)	18.18	1/2	24	1 3/8	24.75	24	1 1/4	7.25	8.00
20	23.00	2.44	3.69	20.00	(6)	(6)	(6)	(6)	20.20	1/2	24	1 3/8	27.00	24	1 1/4	7.50	8.50
24	27.25	2.69	4.12	24.00	(6)	(6)	(6)	(6)	24.25	1/2	24	1 3/8	32.00	24	1 1/2	8.25	9.50

GENERAL NOTES:

- (a) Dimensions are in inches.
 - (b) Weld neck flanges NPS 3 and smaller are dimensionally identical to Class 600 flanges and may be so marked.
 - (c) All other dimensions are in accordance with ASME B16.5.
- NOTES:
- (1) Other NPT sizes may be furnished if required.
 - (2) For slip-on and threaded flanges, verify that TT drilling extends to inside diameter of pipe after assembly and is free from burrs.
 - (3) Bolt lengths include allowance for orifice and gasket thickness of 0.25 in. for NPS 1 to NPS 12 and 0.38 in. for NPS 14 to NPS 24.
 - (4) In conformance with ASME B16.5, stud bolt lengths do not include point heights.
 - (5) Bore diameter of weld neck flanges is to be specified by the purchaser.
 - (6) Threaded flanges are furnished in NPS 1 to NPS 8 only.

Table I-2 Class 600 Orifice Flanges, Welding Neck

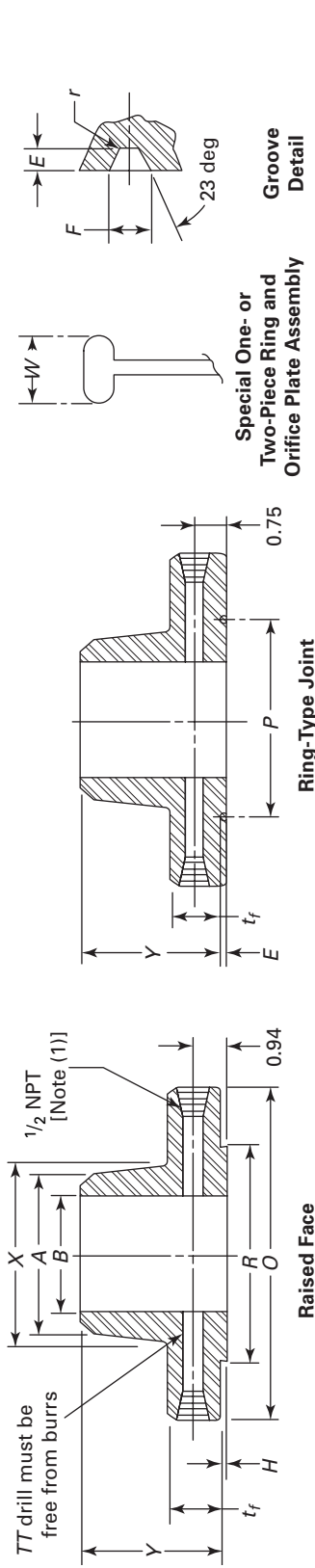

Nominal Pipe Size	Outside Diameter of Raised Face, R	Minimum Thickness of Flange, t _f	Length Through Hub, Y	Height of Raised Face, H	Ring-Type Joint				Hub Diameter Beginning of Chamfer, A	Diameter of Hub, X	Diameter of Pressure Connection, TT	Drilling Template			Length of Stud Bolts [(2), (3)]	
					Groove Diameter, P	Groove Depth, E	Groove Width, F	Radius at Bottom, r				Special Oval Ring Height, W	Number of Bolt Circle Holes	Diameter of Holes		Diameter of Raised Face
1	2.00	1.44	3.19	0.06	2.000	0.250	0.344	0.03	1.00	2.12	1/4	4	0.69	0.75	5/8	5.00
1 1/2	2.88	1.44	3.32	0.06	2.688	0.250	0.344	0.03	1.00	2.75	1/4	4	0.81	0.88	3/4	5.25
2	3.62	1.44	3.32	0.06	3.250	0.312	0.469	0.03	1.06	3.31	1/4	5.00	0.69	0.75	5/8	5.00
2 1/2	4.12	1.44	3.44	0.06	4.000	0.312	0.469	0.03	1.06	3.94	1/4	5.88	0.81	0.88	3/4	5.25
3	5.00	1.44	3.44	0.06	4.875	0.312	0.469	0.03	1.06	4.62	3/8	6.62	0.81	0.88	3/4	5.25
4	6.19	1.50	4.00	0.25	5.875	0.312	0.469	0.03	1.06	6.00	1/2	8.50	1.00	1.00	7/8	6.00
6	8.50	1.88	4.62	0.25	8.312	0.312	0.469	0.03	1.06	8.75	1/2	11.50	1.12	1.12	1	7.00
8	10.62	2.19	5.25	0.25	10.625	0.312	0.469	0.03	1.06	10.75	1/2	13.75	1.25	1.25	1 1/8	7.75
10	12.75	2.50	6.00	0.25	12.750	0.312	0.469	0.03	1.06	13.50	1/2	17.00	1.38	1.38	1 1/4	8.75
12	15.00	2.62	6.12	0.25	15.000	0.312	0.469	0.03	1.06	15.75	1/2	19.25	1.38	1.38	1 1/4	9.00
14	16.25	2.75	6.50	0.25	16.500	0.312	0.469	0.03	1.06	17.00	1/2	20.75	1.50	1.50	1 3/8	9.50
16	18.50	3.00	7.00	0.25	18.500	0.312	0.469	0.03	1.19	19.50	1/2	23.75	1.62	1.62	1 1/2	10.25
18	21.00	29.25	7.25	0.25	21.000	0.312	0.469	0.03	1.19	21.50	1/2	25.75	1.75	1.75	1 5/8	11.00
20	23.00	32.00	7.50	0.25	23.000	0.375	0.531	0.06	1.25	24.00	1/2	28.50	1.75	1.75	1 5/8	11.75
24	27.25	37.00	8.00	0.25	27.250	0.438	0.656	0.06	1.44	28.25	1/2	33.00	2.00	2.00	2 1/8	13.25

GENERAL NOTES:

- (a) Dimensions are in inches.
 - (b) Weldneck flanges NPS 3 and smaller are identical to Class 300 flanges except for bolting and may be used for such service.
 - (c) All other dimensions are in accordance with ASME B16.5.
 - (d) Ring joint flange in NPS 24 will require an angular meter tap as shown in Fig. 2.
- NOTES:
- (1) Other NPT sizes may be furnished if required.
 - (2) Bolt lengths for raised face flanges include allowance for orifice and gasket thickness of 0.25 in. for NPS 1 to NPS 12 and 0.38 in. for NPS 14 to NPS 24. Bolt lengths for ring-type joint flanges include allowance of 0.62 in. for NPS 1 to NPS 10, 0.75 in. for NPS 12 to NPS 18, and 0.88 in. for NPS 20.
 - (3) In conformance with ASME B16.5, stud bolt lengths do not include point heights.
 - (4) Bore is to be specified by the purchaser.

Table I-3 Class 900 Orifice Flanges, Welding Neck

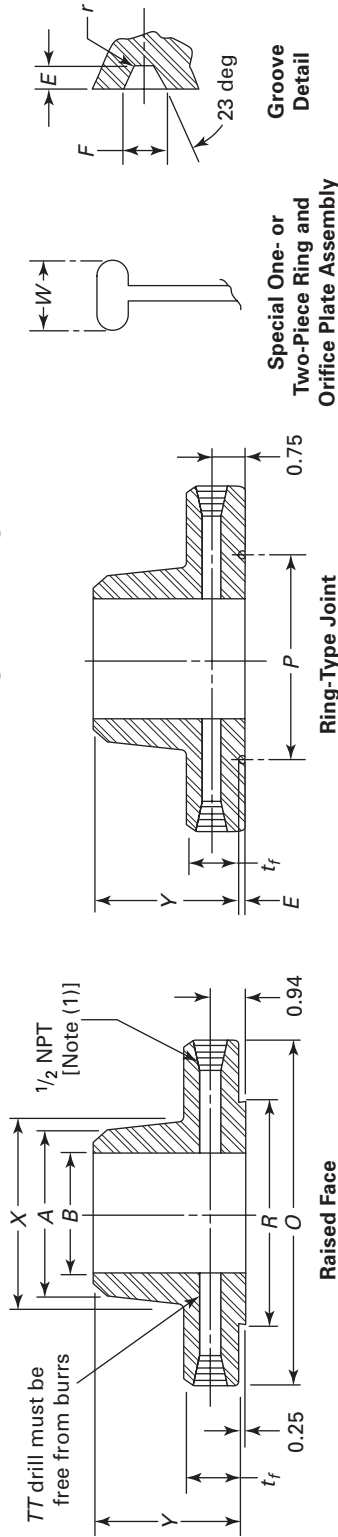

Nominal Pipe Size	Raised Face				Ring-Type Joint					Special One- or Two-Piece Ring and Orifice Plate Assembly			Groove Detail						
	Outside Diameter of Raised Face, R	Outside Diameter of Flange, O	Minimum Thickness of Flange, t_f	Length Through Hub, Y	Groove Number	Groove Depth, E	Groove Width, F	Radius at Bottom, r	Special Oval Ring Height, W	Diameter of Hub, X	Hub Diameter Beginning of Chamfer, A	Bore, B	Diameter of Pressure Connection, TT	Diameter of Bolt Circle	Number of Holes	Diameter of Holes	Length of Stud Bolts [(2), (3)]		
1	5.00	9.50	1.50	4.00	R31	4.875	0.312	0.469	0.03	1.06	3.50	(4)	$\frac{3}{8}$	7.50	8	1.00	$\frac{7}{8}$	6.00	6.50
1½	6.19	11.50	1.75	4.50	R37	5.875	0.312	0.469	0.03	1.06	4.50	(4)	$\frac{1}{2}$	9.25	8	1.25	$\frac{1}{8}$	7.00	7.50
2	8.50	15.00	2.19	5.50	R45	8.312	0.312	0.469	0.03	1.06	6.63	(4)	$\frac{1}{2}$	12.50	12	1.25	$\frac{1}{8}$	7.75	8.25
8	10.62	18.50	2.50	6.38	R49	10.625	0.312	0.469	0.03	1.06	8.63	(4)	$\frac{1}{2}$	15.50	12	1.50	$\frac{3}{8}$	9.00	9.50
10	12.75	21.50	2.75	7.25	R53	12.750	0.312	0.469	0.03	1.06	10.75	(4)	$\frac{1}{2}$	18.50	16	1.50	$\frac{1}{2}$	9.50	10.00
12	15.00	24.00	3.12	7.88	R57	15.000	0.312	0.469	0.03	1.06	12.75	(4)	$\frac{1}{2}$	21.00	20	1.50	$\frac{3}{8}$	10.25	10.75
14	16.25	25.25	3.38	8.38	R62	16.500	0.438	0.656	0.06	1.31	14.00	(4)	$\frac{1}{2}$	22.00	20	1.62	$\frac{1}{2}$	11.00	11.50
16	18.50	27.75	3.50	8.50	R66	18.500	0.438	0.656	0.06	1.44	16.00	(4)	$\frac{1}{2}$	24.25	20	1.75	$\frac{1}{8}$	11.50	12.00
18	21.00	31.00	4.00	9.00	R70	21.000	0.500	0.781	0.06	1.56	18.00	(4)	$\frac{1}{2}$	27.00	20	2.00	$\frac{1}{8}$	13.00	13.75
20	23.00	33.75	4.25	9.75	R74	23.000	0.500	0.781	0.06	1.56	20.00	(4)	$\frac{1}{2}$	29.50	20	2.12	2	14.00	14.75
24	27.25	41.00	5.50	11.50	R78	27.250	0.625	1.062	0.09	1.88	24.00	(4)	$\frac{1}{2}$	35.50	20	2.62	$\frac{1}{2}$	17.50	18.50

For NPS 2½ and smaller, use Class 1500.

GENERAL NOTES:

- (a) Dimensions are in inches.
 - (b) All other dimensions are in accordance with ASME B16.5.
 - (c) Ring joint flanges larger than NPS 12 will require angular meter taps as shown in Fig. 2.
- NOTES:**
- (1) Other NPT sizes may be furnished if required.
 - (2) In conformance with ASME B16.5, stud bolt lengths do not include point heights.
 - (3) Bolt lengths for raised face flanges include allowance for orifice and gasket thickness of 0.25 in. for NPS 3 to NPS 12 and 0.38 in. for NPS 14 to NPS 24. Bolt lengths for ring-type joint flanges include allowance of 0.62 in. for NPS 3 to NPS 10 and 0.75 in. for NPS 12.
 - (4) Bore is to be specified by the purchaser.

Table I-5 Class 2500 Orifice Flanges, Welding Neck

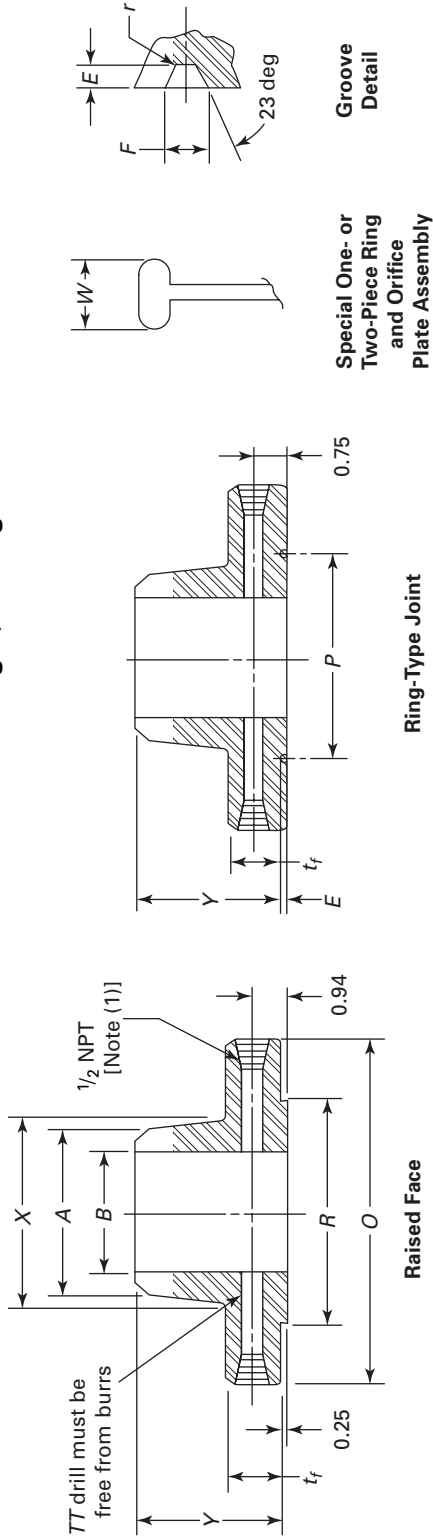

Nominal Pipe Size	Outside Diameter of Raised Face, R	Outside Diameter of Flange, O	Minimum Thickness of Flange, t_f	Length Through Hub, Y	Groove Number	Groove Depth, E	Groove Width, F	Radius at Bottom, r	Special Ring Height, W	Diameter of Hub, X	Hub Diameter Beginning of Chamfer, A	Hub Diameter, B	Diameter of Connection, TT	Drilling Template			Length of Stud Bolts [(2), (3)]		
														Diameter of Bolt Circle	Number of Holes	Diameter of Holes			
1	2.00	6.25	1.50	3.62	R18	0.250	0.344	0.03	1.00	2.25	1.32	(4)	1/4	4.25	4	1.00	7/8	6.00	6.25
1 1/2	2.88	8.00	1.75	4.38	R23	0.312	0.469	0.03	1.06	3.12	1.90	(4)	1/4	5.75	4	1.25	1 1/8	7.00	7.50
2	3.62	9.25	2.00	5.00	R26	0.312	0.469	0.03	1.06	3.75	2.38	(4)	1/4	6.75	8	1.12	1	7.25	7.75
2 1/2	4.12	10.50	2.25	5.62	R28	0.375	0.531	0.06	1.19	4.50	2.88	(4)	1/4	7.75	8	1.25	1 1/8	8.00	8.50
3	5.00	12.00	2.62	6.62	R32	0.375	0.531	0.06	1.19	5.25	3.50	(4)	3/8	9.00	8	1.38	1 1/4	9.00	9.50
4	6.19	14.00	3.00	7.50	R38	0.438	0.656	0.06	1.31	6.50	4.50	(4)	1/2	10.75	8	1.62	1 1/2	10.25	10.75
6	8.50	19.00	4.25	10.75	R47	0.500	0.781	0.06	1.44	9.25	6.63	(4)	1/2	14.50	8	2.12	2	13.75	14.50
8	10.62	21.75	5.00	12.50	R51	0.562	0.906	0.06	1.56	12.00	8.63	(4)	1/2	17.25	12	2.12	2	15.25	16.00
10	12.75	26.50	6.50	16.50	R55	0.688	1.188	0.09	1.88	14.75	10.75	(4)	1/2	21.25	12	2.62	2 1/2	19.25	20.25
12	15.00	30.00	7.25	18.25	R60	0.688	1.312	0.09	2.00	17.38	12.75	(4)	1/2	24.38	12	2.88	2 3/4	21.25	22.50

GENERAL NOTES:

- (a) Dimensions are in inches.
 - (b) All other dimensions are in accordance with ASME B16.5.
 - (c) Ring joint flanges larger than NPS 3 will require angular meter taps as shown in Fig. 2.
- NOTES:**
- (1) Other NPT sizes may be furnished if required.
 - (2) In conformance with ASME B16.5, stud bolt lengths do not include point heights.
 - (3) Bolt lengths for raised face flanges include allowance for orifice and gasket thickness of 0.25 in. for NPS 1 to NPS 12. Bolt lengths for ring-type joint flanges include allowance of 0.62 in. for NPS 1 to NPS 3.
 - (4) Bore is to be specified by the purchaser.

MANDATORY APPENDIX II DIMENSIONAL DATA FOR CLASS 400 FLANGES IN U.S. CUSTOMARY UNITS

This Appendix is an integral part of ASME B16.36-2009, and it is placed after the main text for convenience. Table II-1, included in this Appendix, provides dimensional data in U.S. Customary units for Class 400 flanges.

Table II-1 Class 400 Orifice Flanges, Welding Neck

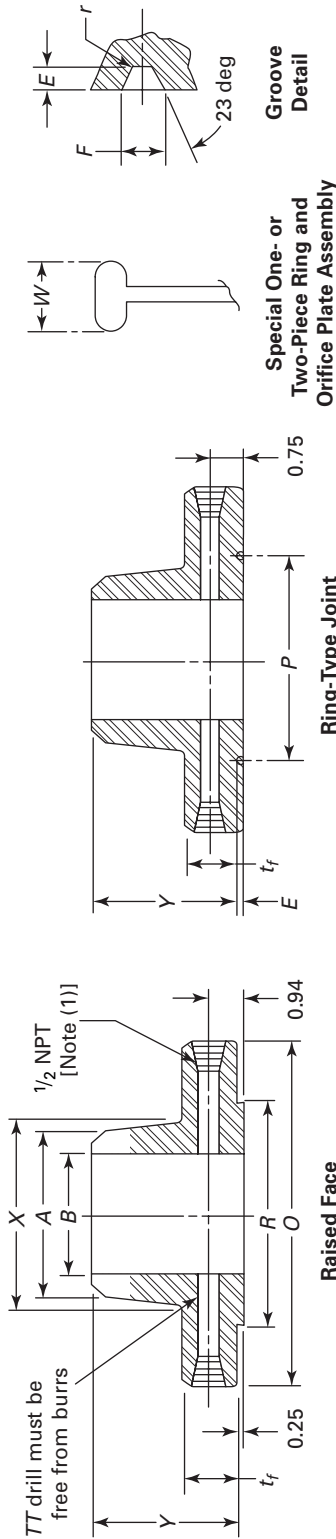

Nominal Pipe Size	Outside Diameter of Raised Face, R	Minimum Thickness of Flange, t _f	Length Through Hub, Y	Groove Number	Pitch Diameter, P	Groove Depth, E	Groove Width, F	Radius at Bottom, r	Special Height, W	Diameter of Hub, X	Hub Diameter Beginning of Chamfer, A	Bore, B	Diameter of Pressure Connection, TT	Drilling Template		Length of Stud Bolts [(2), (3)]
														Diameter of Bolt Circle	Diameter of Holes	
1	6.19	1.50	3.50	R37	5.875	0.312	0.469	0.03	1.06	5.75	4.50	(4)	1/2	7.88	8	5.50
1 1/2	8.50	1.62	4.06	R45	8.312	0.312	0.469	0.03	1.06	8.12	6.63	(4)	1/2	10.62	12	6.25
2	10.62	1.88	4.62	R49	10.625	0.312	0.469	0.03	1.06	10.25	8.63	(4)	1/2	13.00	12	6.75
2 1/2	12.75	2.12	4.88	R53	12.750	0.312	0.469	0.03	1.06	12.62	10.75	(4)	1/2	15.25	16	7.50
3	15.00	2.25	5.38	R57	15.000	0.312	0.469	0.03	1.06	14.75	12.75	(4)	1/2	17.75	16	8.00
4	16.25	2.39	5.88	R61	16.500	0.312	0.469	0.03	1.06	16.75	14.00	(4)	1/2	20.25	20	8.25
6	18.50	2.50	6.00	R65	18.500	0.312	0.469	0.03	1.19	19.00	16.00	(4)	1/2	22.50	20	8.75
8	21.00	2.62	6.50	R69	21.000	0.312	0.469	0.03	1.19	21.00	18.00	(4)	1/2	24.75	24	9.25
10	23.00	2.75	6.62	R73	23.000	0.375	0.531	0.06	1.25	23.12	20.00	(4)	1/2	27.00	24	9.75
12	27.25	3.00	6.88	R77	27.250	0.438	0.656	0.06	1.44	27.62	24.00	(4)	1/2	32.00	24	11.00

For NPS 3 and smaller, use Class 600.

GENERAL NOTES:

- (a) Dimensions are in inches.
 - (b) All other dimensions are in accordance with ASME B16.5.
 - (c) Ring joint flange in NPS 24 will require an angular meter tap as shown in Fig. 2.
- NOTES:
- (1) Other NPT sizes may be furnished if required.
 - (2) In conformance with ASME B16.5, stud bolt lengths do not include point heights.
 - (3) Bolt lengths for raised face flanges include allowance for orifice and gasket thickness of 0.25 in. for NPS 4 to NPS 12 and 0.38 in. for NPS 14 to NPS 24. Bolt lengths for ring-type joint flanges include allowance of 0.62 in. for NPS 4 to NPS 10, 0.75 in. for NPS 12 to NPS 18, and 0.88 in. for NPS 20.
 - (4) Bore is to be specified by the purchaser.

MANDATORY APPENDIX III REFERENCES

The following is a list of publications referenced in this Standard. The latest editions of ASME publications are to be used.

ASME B1.20.1, Pipe Threaded, General Purpose (Inch)

ASME B16.5, Pipe Flanges and Flanged Fittings

ASME B16.11, Forged Fittings, Socket-Welding and Threaded

ASME B16.21, Nonmetallic Gaskets for Pipe Flanges

ASME Boiler and Pressure Vessel Code: Section I, Power Boilers; Section II, Materials; Section III, Nuclear Power Plant Components; Section VIII, Divisions 1 and 2, Pressure Vessels

Publisher: The American Society of Mechanical Engineers (ASME), Three Park Avenue, New York,

NY 10016-5990; Order Department: 22 Law Drive, P.O. Box 2300, Fairfield, NJ 07007-2300 (www.asme.org)

ISO 9000:2005, Quality management systems — Fundamentals and vocabulary

ISO 9001:2008, Quality management systems — Requirements

ISO 9004:2000, Quality management systems — Guidelines for performance improvements

Publisher: International Organization for Standardization (ISO), 1 ch. de la Voie-Creuse, Case postale 56, CH-1211 Genève 20, Switzerland/Suisse (www.iso.org)

NONMANDATORY APPENDIX A QUALITY SYSTEM PROGRAM

The products manufactured in accordance with this Standard shall be produced under a quality system program following the principles of an appropriate standard from the ISO 9000 series.¹ A determination of the need for registration, certification, or both, of the product

¹ The series is also available from the American National Standards Institute (ANSI) and the American Society for Quality (ASQ) as American National Standards that are identified by a prefix "Q" replacing the prefix "ISO." Each standard of the series is listed under Mandatory Appendix III.

manufacturer's quality system program by an independent organization shall be the responsibility of the manufacturer. The detailed documentation demonstrating program compliance shall be available to the purchaser at the manufacturer's facility. A written summary description of the program utilized by the product manufacturer shall be available to the purchaser upon request. The product manufacturer is defined as the entity whose name or trademark appears on the product in accordance with the marking or identification requirements of this Standard.

B16 AMERICAN NATIONAL STANDARDS FOR PIPING, PIPE FLANGES, FITTINGS, AND VALVES

Gray Iron Pipe Flanges and Flanged Fittings (Classes 25, 125, and 250)	B16.1-2005
Malleable Iron Threaded Fittings: Classes 150 and 300.....	B16.3-2006
Gray Iron Threaded Fittings: Classes 125 and 250	B16.4-2006
Pipe Flanges and Flanged Fittings NPS ½ Through NPS 24 Metric/Inch Standard.....	B16.5-2009
Factory-Made Wrought Butt welding Fittings.....	B16.9-2007
Face-to-Face and End-to-End Dimensions of Valves	B16.10-2000 (R2009)
Forged Fittings, Socket-Welding and Threaded	B16.11-2009
Cast Iron Threaded Drainage Fittings	B16.12-2009 (R2014)
Ferrous Pipe Plugs, Bushings, and Locknuts with Pipe Threads	B16.14-1991
Cast Copper Alloy Threaded Fittings.....	B16.15-2006
Cast Copper Alloy Solder Joint Pressure Fittings	B16.18-2001 (R2005)
Metallic Gaskets for Pipe Flanges: Ring-Joint, Spiral-Wound, and Jacketed.....	B16.20-2007
Nonmetallic Flat Gaskets for Pipe Flanges.....	B16.21-2005
Wrought Copper and Copper Alloy Solder Joint Pressure Fittings.....	B16.22-2001 (R2005)
Cast Copper Alloy Solder Joint Drainage Fittings: DWV.....	B16.23-2002 (R2006)
Cast Copper Alloy Pipe Flanges and Flanged Fittings: Classes 150, 300, 600, 900, 1500, and 2500	B16.24-2006
Butt welding Ends.....	B16.25-2007
Cast Copper Alloy Fittings for Flared Copper Tubes.....	B16.26-2006
Wrought Steel Butt welding Short Radius Elbows and Returns.....	B16.28-1994
Wrought Copper and Wrought Copper Alloy Solder Joint Drainage Fittings — DWV.....	B16.29-2007
Manually Operated Metallic Gas Valves for Use in Gas Piping Systems up to 125 psi (Sizes NPS ½ Through NPS 2)	B16.33-2002 (R2007)
Valves — Flanged, Threaded, and Welding End.....	B16.34-2004
Orifice Flanges	B16.36-2009
Large Metallic Valves for Gas Distribution Manually Operated, NPS 2½ (DN 65) to NPS 12 (DN 300), 125 psig (8.6 bar) Maximum.....	B16.38-2007
Malleable Iron Threaded Pipe Unions: Classes 150, 250, and 300.....	B16.39-2009
Manually Operated Thermoplastic Gas Shutoffs and Valves in Gas Distribution Systems	B16.40-2008
Functional Qualification Requirements for Power Operated Active Valve Assemblies for Nuclear Power Plants.....	B16.41-1983 (R1989)
Ductile Iron Pipe Flanges and Flanged Fittings: Classes 150 and 300	B16.42-1998 (R2006)
Manually Operated Metallic Gas Valves for Use in Aboveground Piping Systems Up To 5 PSI	B16.44-2002 (R2007)
Cast Iron Fittings for Solvent® Drainage Systems.....	B16.45-1998 (R2006)
Large Diameter Steel Flanges NPS 26 Through NPS 60 Metric/Inch Standard	B16.47-2006
Steel Line Blanks.....	B16.48-2005
Factory-Made Wrought Steel Butt welding Induction Bends for Transportation and Distribution Systems.....	B16.49-2007
Wrought Copper and Copper Alloy Braze-Joint Pressure Fittings	B16.50-2001 (R2008)

The ASME Publications Catalog shows a complete list of all the Standards published by the Society. For a complimentary catalog, or the latest information about our publications, call 1-800-THE-ASME (1-800-843-2763).

ASME Services

ASME is committed to developing and delivering technical information. At ASME's Information Central, we make every effort to answer your questions and expedite your orders. Our representatives are ready to assist you in the following areas:

ASME Press
Codes & Standards
Credit Card Orders
IMEchE Publications
Meetings & Conferences
Member Dues Status

Member Services & Benefits
Other ASME Programs
Payment Inquiries
Professional Development
Short Courses
Publications

Public Information
Self-Study Courses
Shipping Information
Subscriptions/Journals/Magazines
Symposia Volumes
Technical Papers

How can you reach us? It's easier than ever!

There are four options for making inquiries* or placing orders. Simply mail, phone, fax, or E-mail us and an Information Central representative will handle your request.

Mail
ASME
22 Law Drive, Box 2900
Fairfield, New Jersey
07007-2900

Call Toll Free
US & Canada: 800-THE-ASME
(800-843-2763)
Mexico: 95-800-THE-ASME
(95-800-843-2763)
Universal: 973-882-1167

Fax—24 hours
973-882-1717
973-882-5155

E-Mail—24 hours
Infocentral@asme.org

* Information Central staff are not permitted to answer inquiries about the technical content of this code or standard. Information as to whether or not technical inquiries are issued to this code or standard is shown on the copyright page. All technical inquiries must be submitted in writing to the staff secretary. Additional procedures for inquiries may be listed within.

ASME B16.36-2009

ASME B16.36-2009

ISBN-13 : 978-0-7918-3226-4

ISBN-10 : 0-7918-3226-0

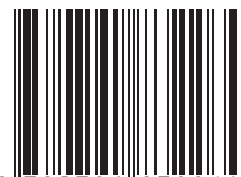

9 780791 832264



J04609